

MATHLETICS



Student Book

SERIES

Geometry



Name _____

Series G – Geometry

Contents

Topic 1 – Lines and angles (pp. 1–6)

Date completed

- lines _____
- classifying angles _____
- measuring angles _____
- hand it over – *apply* _____
- it's all in the timing – *investigate* _____

Topic 2 – 2D shapes (pp. 7–15)

- polygons _____
- quadrilaterals _____
- triangles _____
- circles _____
- the shapes within – *apply* _____
- rip it up – *investigate* _____

Topic 3 – Transformation, tessellation and symmetry (pp. 16–24)

- line symmetry _____
- rotational symmetry _____
- transformation _____
- tessellation _____
- enlargement and reduction _____
- picture perfect – *create* _____
- design diva – *create* _____

Topic 4 – 3D shapes (pp. 25–32)

- types and properties _____
- nets _____
- drawing 3D shapes _____
- to cube or not to cube ... – *investigate* _____
- form an orderly queue – *apply* _____

Series Authors:

Rachel Flenley

Nicola Herring

Lines and angles – lines

These terms are commonly used when we work with lines and angles:

- parallel – these lines are always the same distance apart at every point, they never meet
- perpendicular – these lines intersect at right angles
- diagonal – these are lines within a shape that join a vertex (corner) to another vertex
- intersection – the place where 2 or more lines cross over each other

1 This paper folding activity relies on a thorough understanding of the terms in the box above. Try your hand at it! You will need a thin circular piece of paper with a radius of at least 8 cm.

1 Begin with a circular piece of paper.

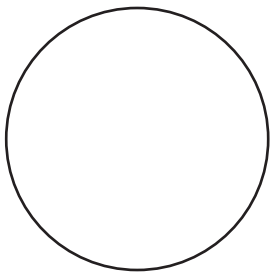

2 Fold the circle in half.

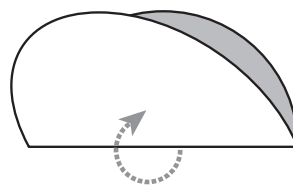

3 Fold A to meet B.

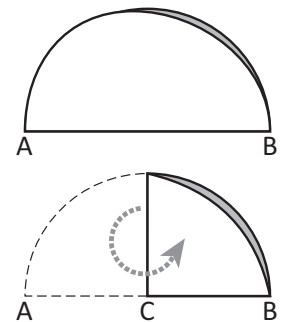

4 Fold B up to D, you've now created point E.

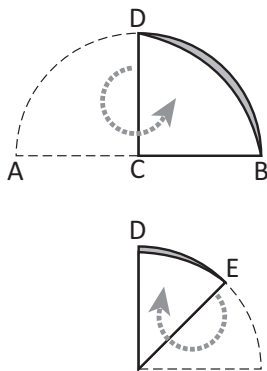

5 Draw a perpendicular line from line CD to point E. Fold to create FE.

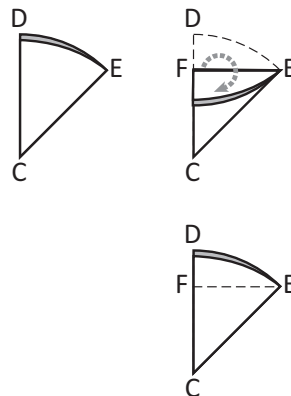

6 Draw a perpendicular line from line CE to point D. Fold to create DG.

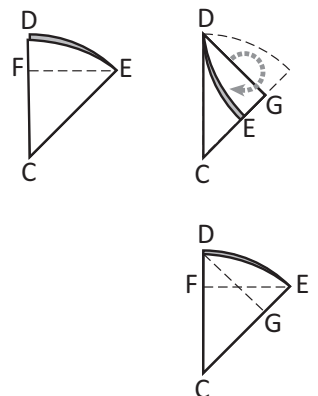

7 Cut along fold lines EF and DG, only to the intersection.

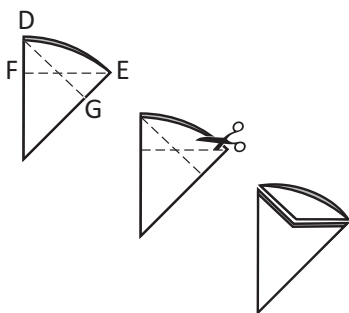

8 Open the shape. What have you made?

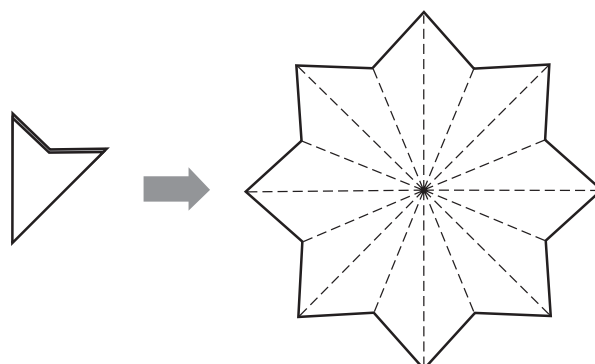

Lines and angles – classifying angles

An angle is the amount of turn between the intersection of two rays (lines).

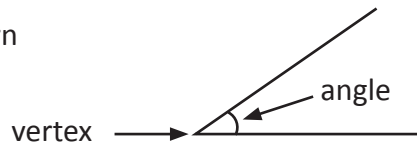



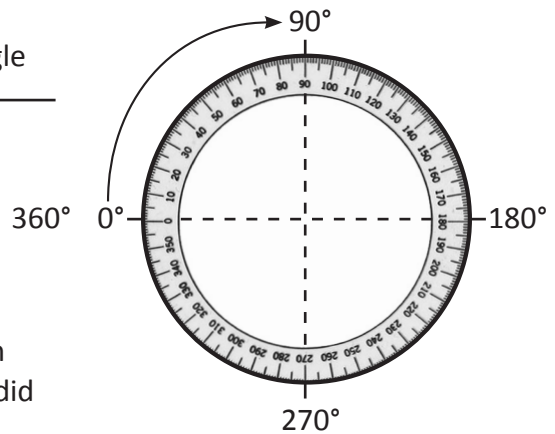

Angles are conventionally measured in degrees on a protractor. 360° is a full turn, 180° is a half turn, and 90° is a quarter turn.

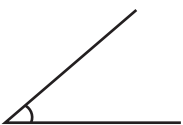
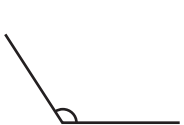

Have you heard someone say, "He did a complete 180° on that."? What do you think they meant? What does, "She did a full 360° " mean?

1 Complete the table and use the information to help you to classify the angles below. Use a maths dictionary to help you work out any unknown terms.

 right angles are _____.	 acute angles are _____ than 90° .	 obtuse angles are _____ than 90° and less than _____.	 straight angles are exactly _____.	 reflex angles are greater than 180° and less than _____.	 revolution angles are exactly _____.
--	---	---	---	--	---

a

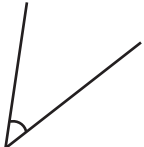

acute angle

b

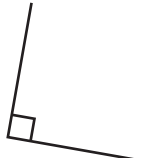

_____ angle

c



_____ angle

d

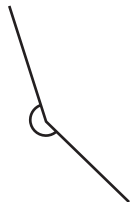

_____ angle

e



_____ angle

f

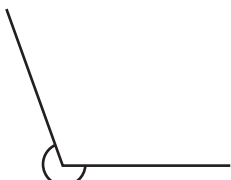

_____ angle

Make sure you check which angle you're meant to be measuring! The little arc tells you here.



2 Look at the interior angles in this shape. Mark any acute angles with a red arc; obtuse angles with a blue arc; reflex angles with a green arc; and right angles with an orange \square :

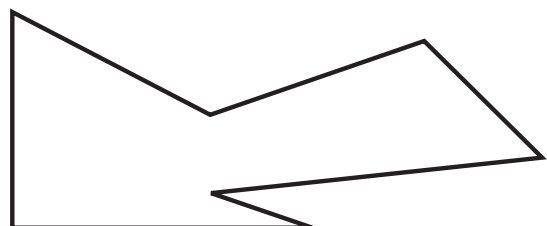

Lines and angles – measuring angles

We use protractors to measure angles.

- 1 Align the baseline on the protractor with one of the lines.
- 2 Line up the vertex of the angle with the centre point of the protractor.
- 3 Measure the distance between the two lines, starting at the 0 and counting round.

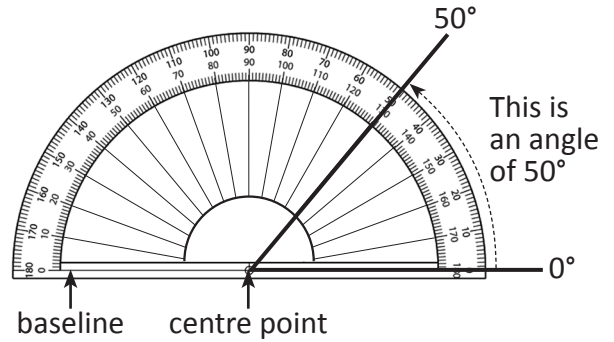

1 Use your protractor to measure these angles. Write the measurements next to the angles.

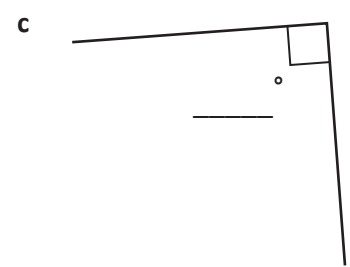
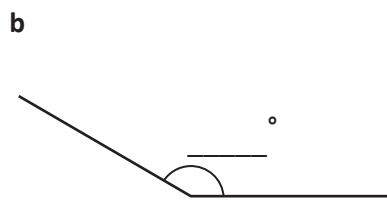
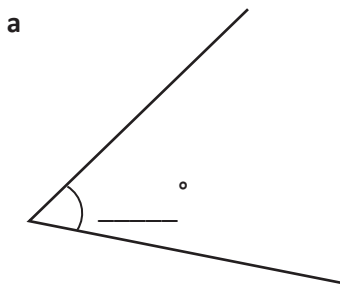

2 Measure the interior angles of this shape. Write the measurements next to each angle. The first one has been done for you.

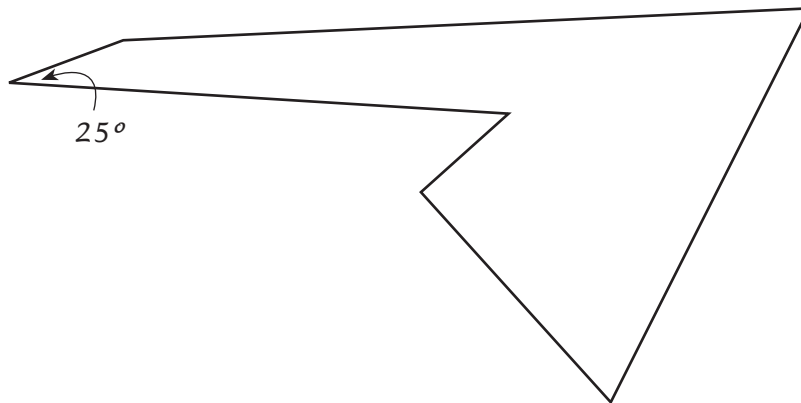

3 List 5 sports or jobs where you think it would be important to consider angles. David Beckham can probably think of at least one.

a _____

b _____





c _____

d _____

e _____

Lines and angles – measuring angles

- 4 Work with a partner on this activity. Take turns predicting where you think the missing ray of the angle should go. Starting at the dot, rule your predictions then measure with a protractor. Mark in the actual angle. Who was closer? Do you get more accurate with practice? Invent more of these on another piece of paper if you have time.

a  b  c  d 

- 5 Look at the clock.

- a What does each 5 minute marker represent in degrees? _____
 b What about each minute? _____

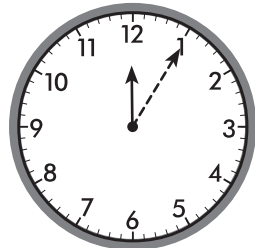

- 6 Make a time that shows an angle between the two hands of:

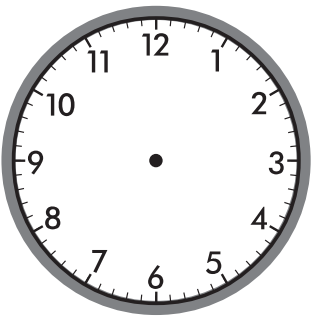
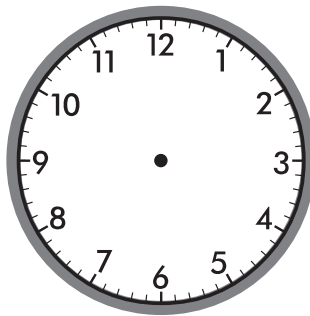
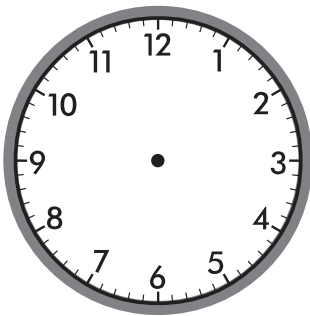
a  b  c 

Decide where your first hand will go, then count round to create the angle.

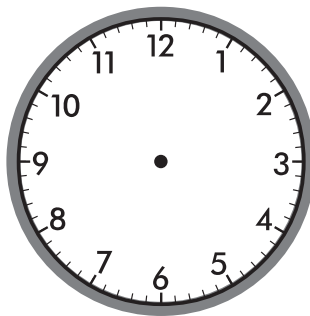
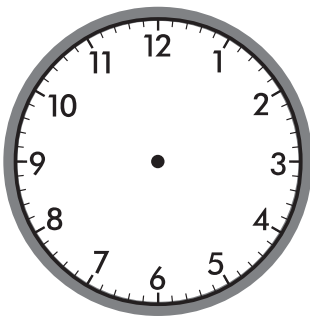

THINK

d  e 



Getting ready



Look at the picture of the hand. What well known angle would you say is approximately formed by the thumb and forefinger?

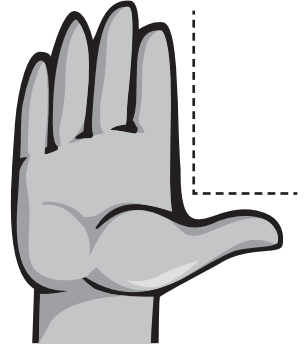

What to do



Spread your hand out in the box below and trace around it. Estimate then measure the angles formed between each finger. The measurements will be approximate only.

Compare your measurements with those of a partner. Are they similar?



Getting ready

You can work with a partner on this activity. You may like to use a clock with movable hands or to use copies of the clock faces below.



What to do

How many times do the hands on a clock form a right angle within a 12-hour period? Show the times on the clocks as you find them.

If you find 10 or more, you've made a great start. 15 or more, you're doing very well. More than 20, you're indeed a Time Lord and people should bow as you pass by.

We have given you the first one to get you started.

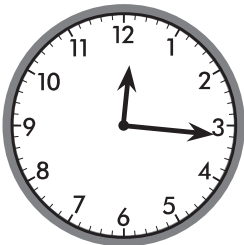

12:16

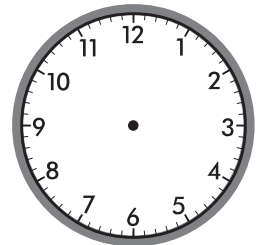
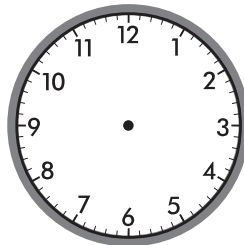
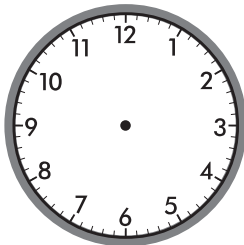

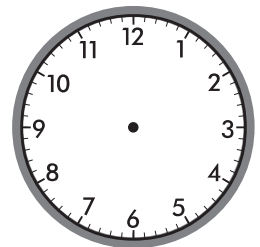
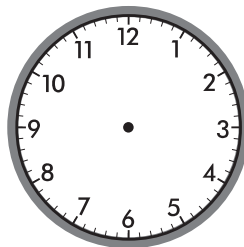
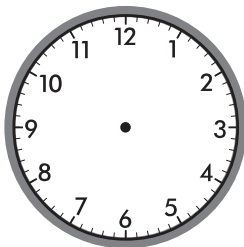
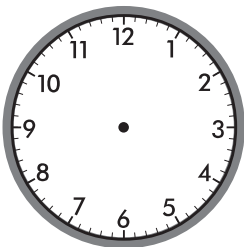

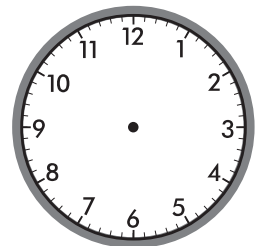
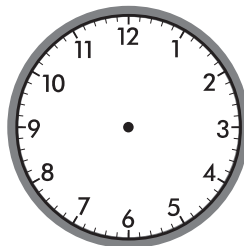
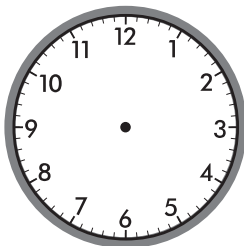
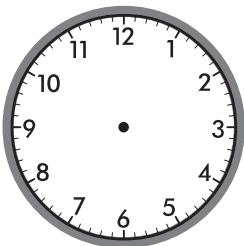

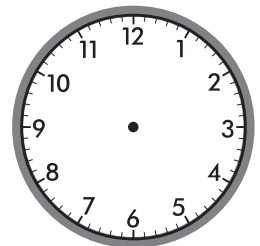
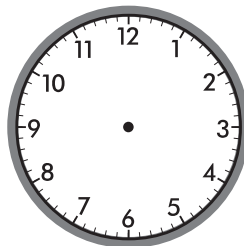
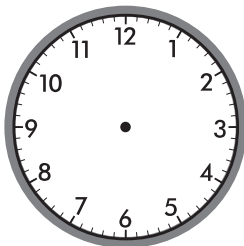
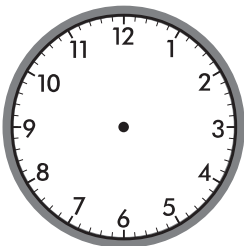

2D shapes – polygons

A polygon is a 2D (flat) shape with 3 or more straight sides. The word comes from the Greek words, *poly* and *gonia*, meaning ‘many angles’.

All polygons are closed – they have no break in their boundaries. They have no curved sides.

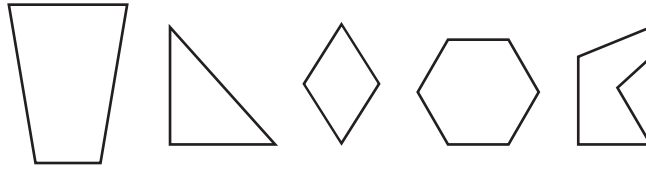

These are polygons.

- 1** It's time for a polygon pop quiz. Read through the questions and answer any you know. Now for the research. You may draw the shapes, use the internet, or a maths dictionary to help you find the answers. If you want to add some excitement, work in small teams and race against other teams. The first correct team wins.

I have 4 equal sides and 4 equal angles.

I'm a

I'm a 3 sided polygon. I have 2 equal sides and angles.

I'm an

I have 5 sides and 5 angles. This makes me a pentagon.

My angles add to

I have 6 sides and 6 angles. I'm a hexagon.

My angle sum is

I have 4 sides and 4 angles. I have 1 pair of parallel lines.

I'm a

I have 12 sides and 12 angles.

I'm a

I'm a quadrilateral. Both pairs of opposite sides are parallel.

I'm a

I'm a triangle with 1 axis of symmetry. Draw and label me.

What does the phrase 'angle sum' mean?

I'm an equilateral triangle. Draw me.

There may be more than one right answer for some of these.



CHECK

2D shapes – polygons



This is a regular pentagon. The 5 sides and angles are equal.

Irregular polygons have the same number of sides as regular polygons but their sides are not of an equal length and their angles are not equal.

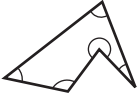

This is an irregular pentagon.

- 2 Here is a regular quadrilateral. It has 4 sides and 4 right angles. What do these angles add to? _____
Now draw an irregular quadrilateral. Measure and add the interior angles of the shapes. What do you notice?

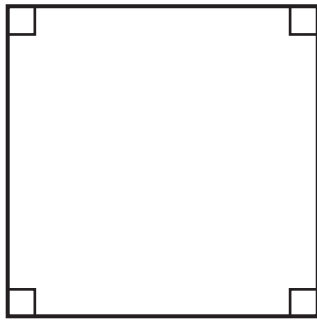

- 3 Here is a regular pentagon. It has 5 sides of equal length and its angle sum is 540° . Draw an irregular pentagon. Measure and add the angles. What do you notice?

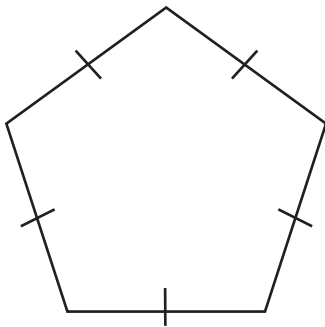

- 4 Draw an irregular hexagon with 4 right angles. Mark the right angles. Compare your drawing with others'.
Are they the same?
If they are different, does that mean one of you is wrong?

2D shapes – polygons

When we study polygons, we use a range of terms to describe and distinguish their properties. Look at this rhombus. We can list its properties:

- it is a 4 sided shape
- all sides are equal
- the opposite sides are parallel
- the opposite angles are equal
- when we draw in the diagonals, they cross each other at right angles

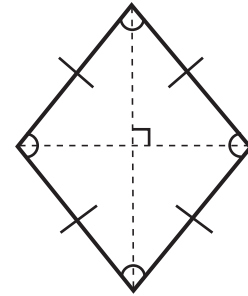

What does all this mean?

5 Follow the instructions:

- a Well, the 4 sided thing is pretty straightforward. Draw a rectangle. Make 2 of the sides 8 cm and 2 of the sides 4 cm. How many sides does it have?

_____ (Fancy that ...)

- b When we say the sides are equal we mean they are the same length. We show equal sides by crossing them with | or =. Mark the equal lines on your rectangle: one set with | and the other set with =.
- c We often use the terms **opposite** and **adjacent**. Opposite means facing and adjacent means next to. Trace one of the sides of your rectangle with a red pencil. Now trace the opposite side with a blue pencil. Trace a line that is adjacent to the red line with green.
- d When we say angles are equal we mean that they are the same size. We know all interior angles on a rectangle are 90° (or right angles). This means both opposite and adjacent angles are equal. Mark the right angles on your rectangle.
- e Lines that are opposite are also parallel. This means they are always the same distance apart and never meet. How many sets of parallel lines does your rectangle have? _____
- f When we talk about diagonals, we mean the lines we can draw from opposite angle to opposite angle. We make these lines dotted to show they are not sides. Mark the diagonals on your rectangle with 2 dotted lines.
- g We can measure the angles where diagonals intersect. On a rectangle, opposite angles on the diagonal should be equal. Use a protractor to check that yours are. Mark the equal angles with \sphericalangle or \sphericalcap .

6 Now draw a triangle (any kind), a square or a trapezium. Mark the properties.

2D shapes – quadrilaterals

A quadrilateral is a kind of polygon. It is a closed, flat shape with 4 straight sides and 4 angles. The name comes from the Latin words, *quad* and *latus*, meaning '4 sides'. We know that squares, rhombuses, rectangles and trapeziums are all examples of quadrilaterals. We also know the interior angles of quadrilaterals always add to 360° .

- 1 Use the clues to draw and name these mystery quadrilaterals. All the examples in the box above are represented. You will need to use a protractor and you may also need to research the properties of each quadrilateral.

My sides:	My angles:	My name:
<ul style="list-style-type: none"> • opposite sides are parallel • all sides are of equal length 	<ul style="list-style-type: none"> • all 4 interior angles are right angles (90°) • if you draw in the diagonals, right angles are formed where they intersect 	
<ul style="list-style-type: none"> • opposite sides are parallel and of equal length 	<ul style="list-style-type: none"> • all 4 interior angles are right angles (90°) 	
<ul style="list-style-type: none"> • all 4 sides are equal in length • opposite sides are parallel 	<ul style="list-style-type: none"> • 4 interior angles • opposite angles are equal • if you draw in the diagonals, right angles are formed where they intersect 	
<ul style="list-style-type: none"> • only one pair of opposite sides is parallel 	<ul style="list-style-type: none"> • 4 interior angles • 2 parallel lines = 2 parallel angles 	

- 2 Can a shape be a square, a parallelogram and a rhombus all at the same time? Explain your thinking:

2D shapes – triangles

There are 4 main types of triangles:

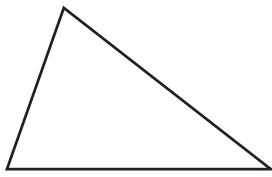

scalene

- all sides different
- all angles unequal

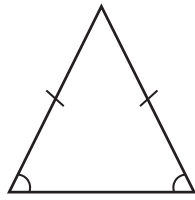

isosceles

- two sides equal
- two angles equal

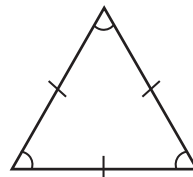

equilateral

- all sides equal
- all angles equal

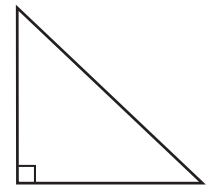

right angle

- has a right angle

We use letters to name the angles and then use these to refer to the lines.

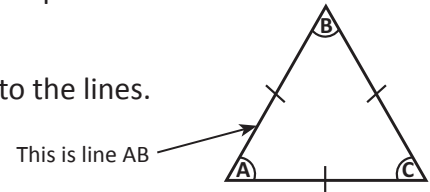

1

In the box below, draw a triangle with three 5 cm sides and three angles of 60° . Label the triangle ABC as in the example above.

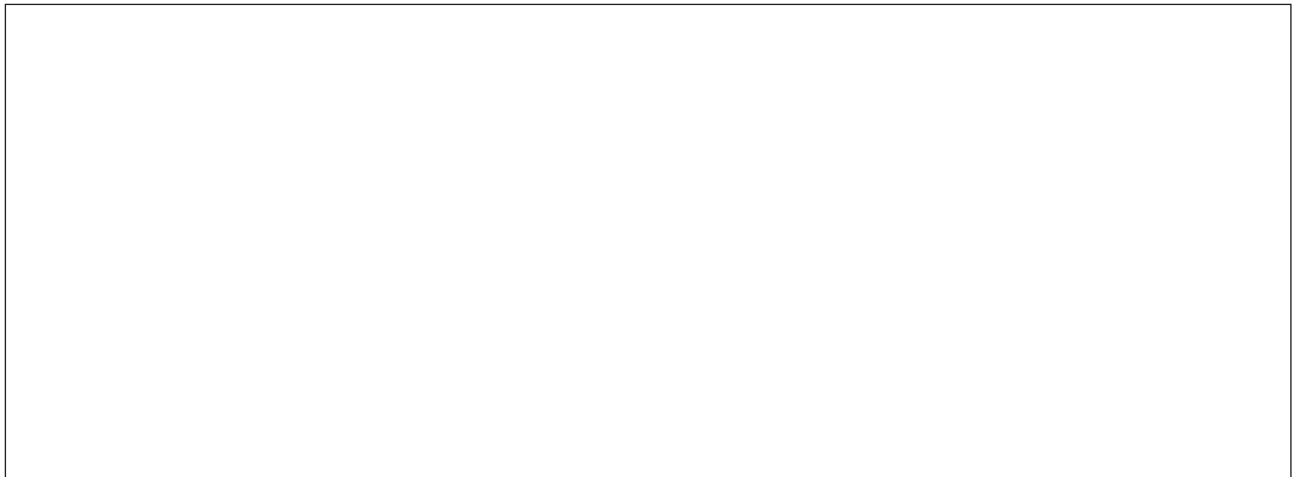

- a What do the angles add to? _____
- b What kind of triangle have you made? _____
- c Using a different colour, extend line AC by 2 cm and mark the new point as D. Draw a new line BD.
- d Are all the angles and sides equal? _____
- e What do the angles add to? _____
- f What kind of triangle have you made now? _____

2D shapes – triangles

2 In the right half of the box below, draw a triangle with the following specifications:

Line AC: horizontal, 6 cm

Angle A: 90°

Line AB: vertical, 5 cm (rule along the dotted line)

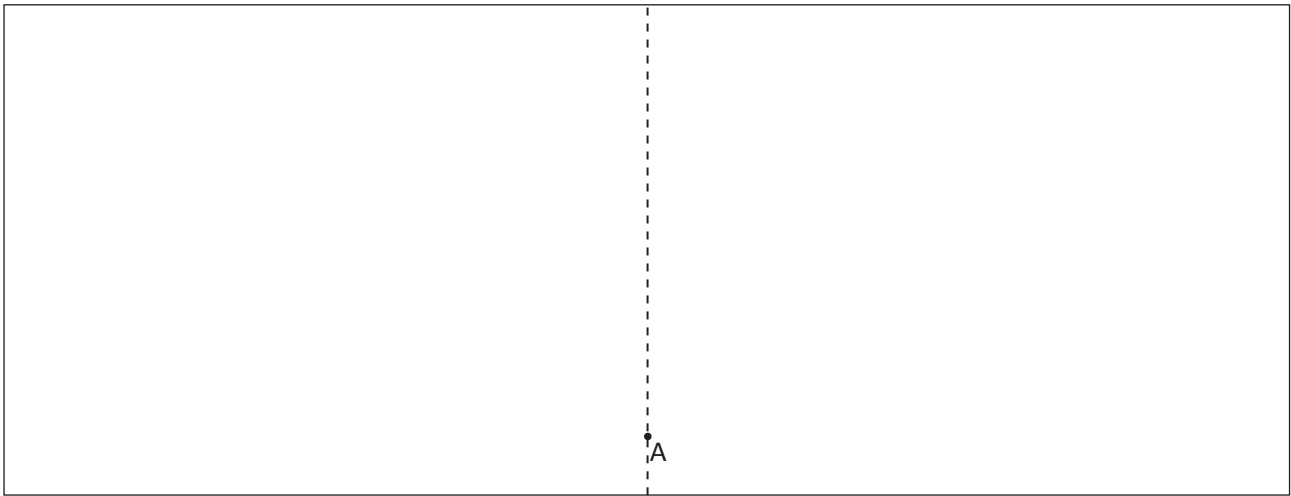

- a Draw line BC. Measure and record the length of sides and the size of the angles.
- b What do the angles add to? _____
- c What kind of triangle have you made? _____
- d Draw a 6 cm line AD. This will take the triangle into the left side of the box. Draw line DB. Measure and record the length of sides and the size of the angles.
- e Which angles are equal? _____
- f Which sides are equal? _____
- g What do the angles of the triangle add to? _____
- h What kind of triangle have you made now? _____

3 What conclusions can you draw from this about the relationships between the sides and angles?

Did you know that the greatest angle is always opposite the longest line? Test it out on some triangles to see if it's true.



DISCOVER

2D shapes – circles

A circle is also a 2D shape. It is a curve with its points a fixed distance from the **centre**.

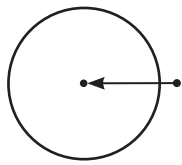

centre: this is the point in the middle

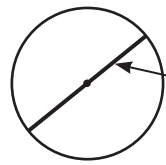

diameter: the distance from the edge of a circle through the middle to the opposite edge

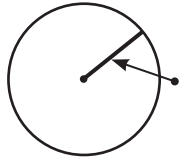

radius: the distance from the centre to the circle's edge

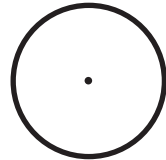

circumference: the distance around the circle

- 1 Using a compass, draw 3 circles with different radii (radiuses). Measure their radii and diameters and label them.



- 2 From this, what do you notice about the relationship between the radius and the diameter of circles?

- 3 Follow the instructions to create this circle pattern. On a separate piece of paper, draw a line like the one below, in the middle of the page.

- a Place the compass point on the dot on the line and draw a circle.
- b Using the intersection points on the line as the centre, draw a same sized circle either side of the first circle.
- c Add 4 more circles using the new points of intersection as your compass point. Make sure they are also the same size.
- d Colour the design you've made.





Getting ready

We can construct regular shapes inside circles. You will use what you know about angles and degrees to help you. You'll also need a protractor and a compass.

How many degrees are there in a circle? There are _____.



What to do

We are going to make a regular hexagon inside this circle.

How many sides and angles do hexagons have? They have 6 sides and 6 angles. We will therefore need to divide the angles in the circle by 6.

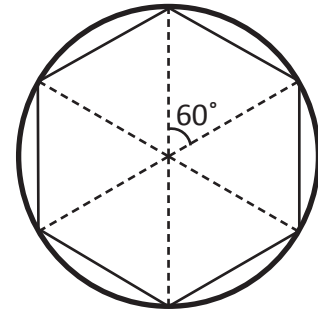

$$\underline{\hspace{2cm}} \div 6 = 60^\circ$$

So, from the centre we draw 6 lines, each with angles of 60° between them. Extend the lines to the edge of the circle.

Now, join the points where the lines meet the circle edge. Ta da!



What to do next

It's your turn. Use the circles below to make a regular octagon and a regular decagon. How many angles will you need for each shape? What will their angle size be?

Place your protractor along the line in the circle with the centre point of the protractor on the dot. Measure the angle needed and draw your next line. Repeat this process until all lines are drawn.

Join the points where the lines meet the circle. Has it worked?

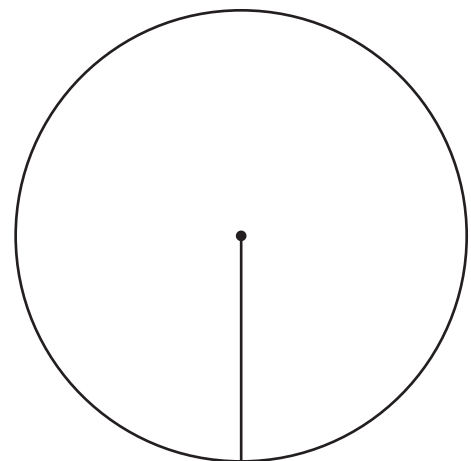
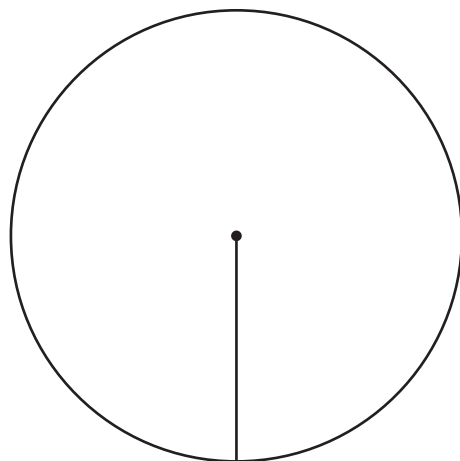

octagon

lines _____

angle _____

decagon

lines _____

angle _____



Getting ready



It is said that all quadrilaterals have an angle sum of 360° . Your job is to prove it without using a protractor.

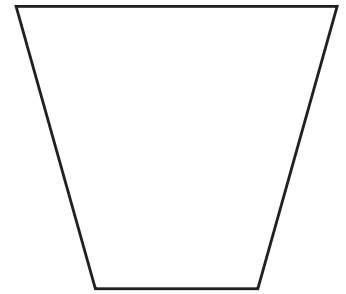

What to do



On a separate piece of paper, draw a quadrilateral such as a square, rectangle, trapezium or rhombus.

Number each corner and then tear the corners out as shown below:

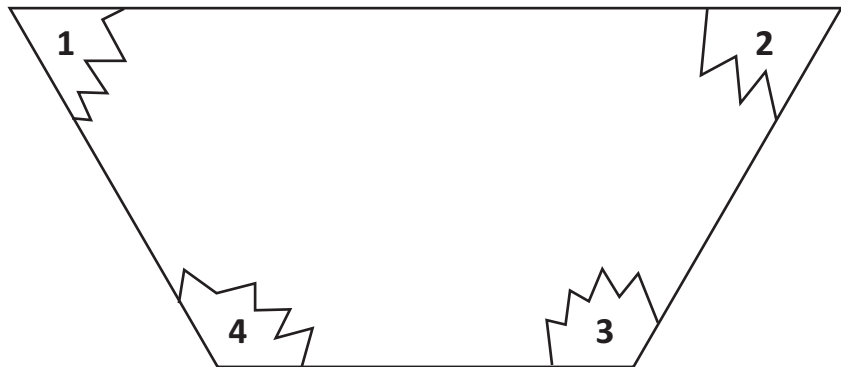

Join the torn corners with the points touching like this.

What do you find?

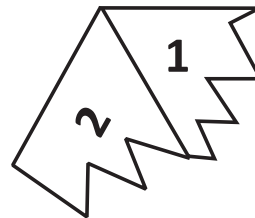

What to do next



Try this experiment with 2 other kinds of quadrilaterals. They can be as irregular as you like.

Transformation, tessellation and symmetry – line symmetry

Reflective or line symmetry describes mirror image, when one half of a shape or picture matches the other exactly. The middle line that divides the two halves is called the line of symmetry. Shapes may have:

no line of symmetry

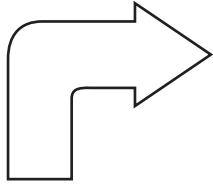

one line of symmetry

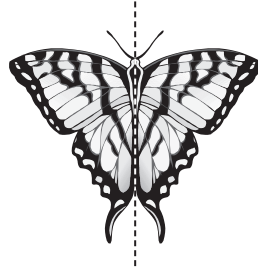

more than one line of symmetry

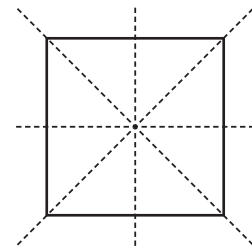

- 1 Lines of symmetry have been drawn on these shapes. Trace over the ones drawn correctly. Cross out any that are incorrect. Add any you think have been missed.

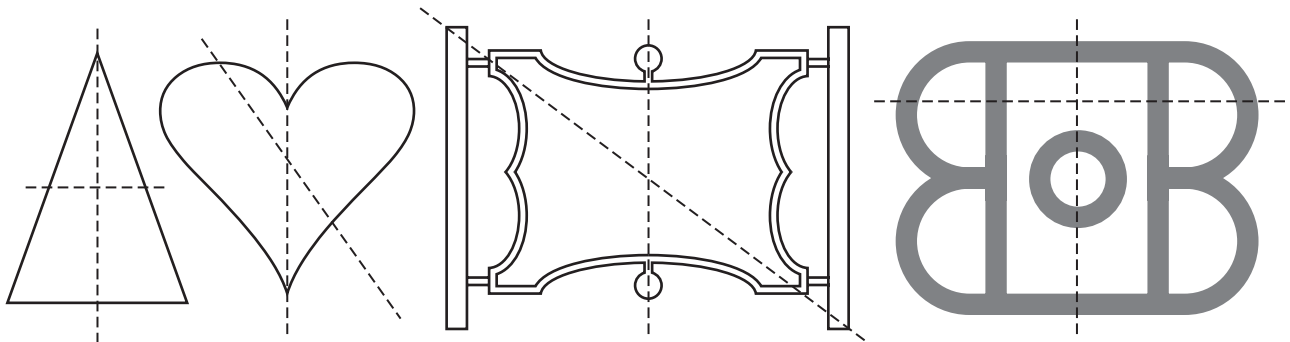

- 2 Colour the missing squares to make each line a line of symmetry:

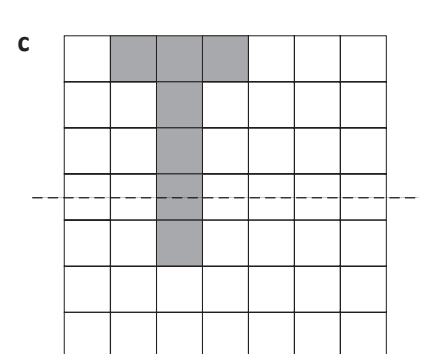
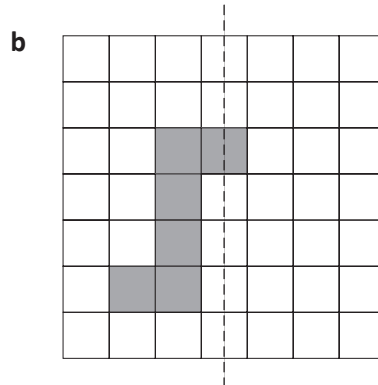
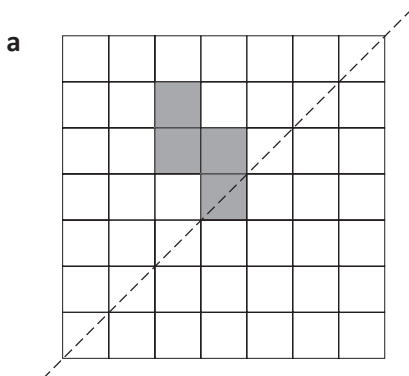

Transformation, tessellation and symmetry – rotational symmetry

A shape has rotational symmetry if it looks the same in different positions when turned from a central point.

This shape has rotational symmetry of order 3. This means it looks exactly the same in 3 different positions.

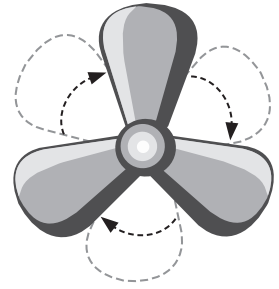

1 Turn these shapes in your head. Do they have rotational symmetry? If so, what is the order?

a

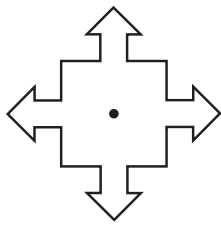

b

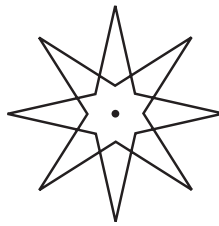

c

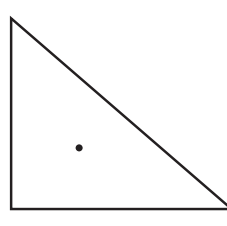

d

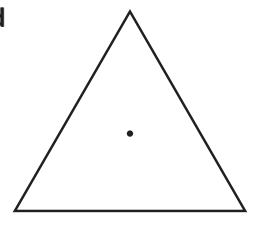

2 A great way to understand rotational symmetry is to use the computer. There are lots of programs you can use. These instructions are for a word processing program:

- Open a new blank document.
- Select a shape from the autoshape menu (in the drawing toolbar) and draw it.
- Select the shape again and you'll see a little green filled circle. This is the rotate tool.
- Turn the shape and watch the dotted lines. Count how many times the shapes match during a full rotation.
- Draw some of the shapes you created below. Note whether they have rotational symmetry and, if so, what order.

Transformation, tessellation and symmetry – transformation

We can transform (move) shapes in many ways. We can:

reflect (flip) them

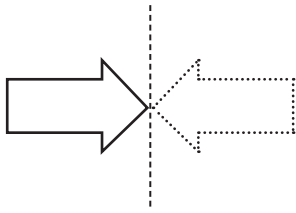

translate (slide) them

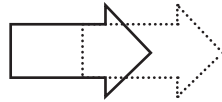

or rotate (turn) them

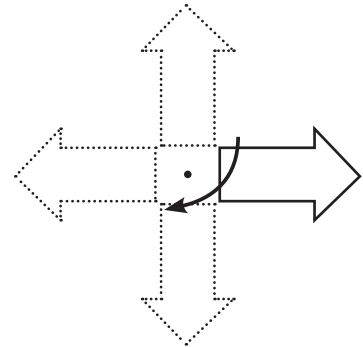

1 Look at these figures. Decide if each figure has been reflected, translated or rotated:

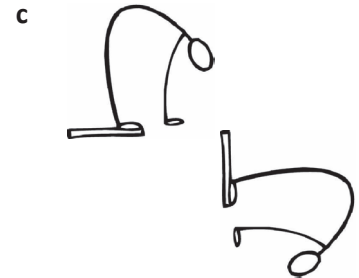

2 When some letters of the alphabet are rotated 180° (in a half circle), they become other letters. (This depends on how you write them of course.) An example of this is d. Turn it halfway around and it becomes p. What other letters can you find that do this?

d → p

3 What is the international three-letter distress symbol? Write it down.
Now, rotate it 180° , then translate it, write it backwards, and write it upside down. What do you notice?
Pretty handy if you're dangling out of a plane, hey!

Transformation, tessellation and symmetry – transformation

- 4 Look at the figure. Draw what it will look like if is reflected. Next, draw what the reflected figure will look like when rotated a quarter turn anticlockwise.



- 5 Find the pattern and continue it:

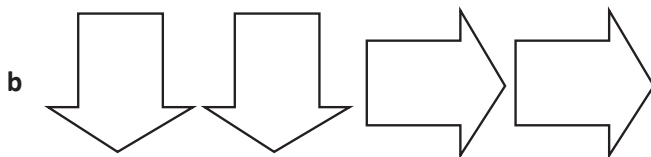
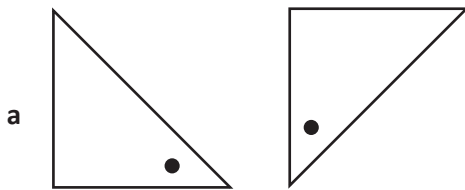

- 6 Some words look the same when they're written backwards. MUM is an example. Can you find some more?

Transformation, tessellation and symmetry – tessellation

Tessellation means covering a surface with a pattern of 2D shapes with no gaps or spaces. When we tessellate shapes, we often flip or turn the shapes so they fit together.

Some shapes will tessellate on their own, some will tessellate if they are teamed with others and some won't tessellate at all.

- 1 Use pattern blocks to find some shape teams that will tessellate and record them here. There are 7 teams. Can you find them all? Here is one example to get you started:

- *large octagons, small squares*

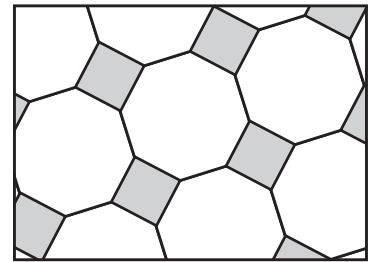

large octagons, small squares

- 2 Look at these regular shapes. Which will tessellate on their own? Colour them. Use pattern blocks if it helps.



Why will these shapes tessellate? Partly it is because their sides are the same length. But regular pentagons have sides the same length, and they won't. So why is it? The answer is in the vertex.

Look at these 4 squares. The corners that join each have an angle of 90° . Together these add to 360° – a full turn. They each take up one quarter of a full turn. We can name this pattern as 4, 4, 4, 4.

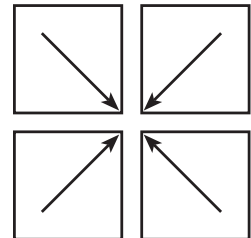

- 3 Look at these tessellations and work out the sum of the angles at the vertex:

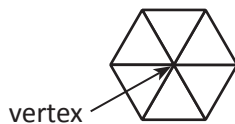

- The angle sum of an equilateral triangle is _____ $^\circ$.
- Each angle measures _____ $^\circ$.
- _____ triangles meet at the vertex.
- Their angle sum is _____ $^\circ$.
- We can name this pattern as 3, 3, __, __, __, __ as there are six 3-sided shapes.



- The angle sum of a regular hexagon is _____ $^\circ$.
- Each angle measures _____ $^\circ$.
- _____ hexagons meet at the vertex.
- Their angle sum is _____ $^\circ$.
- We can name this pattern as __, __, __ as there are three 6-sided shapes.

Transformation, tessellation and symmetry – tessellation

- 4 Look at the vertex in this semi-regular tessellation of octagons and squares. How many angles meet? What are their size? Does the 360° rule work? Explain your reasoning.

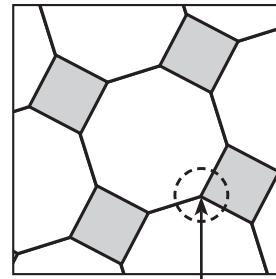

This is the vertex



- 5 What about this hexagon/triangle tessellation? Explain how this works.

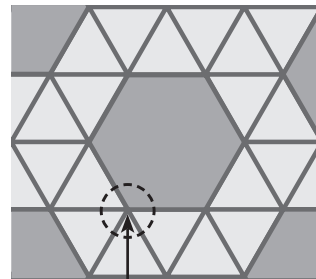

This is the vertex

HINT: There are 1080° in an octagon and 720° in a hexagon. We need to divide 1080° by 8 to find each angle in the octagon.



- 6 The angle size of a regular pentagon is 108° . These won't tessellate because $108^\circ + 108^\circ + 108^\circ + 108^\circ + 108^\circ = 540^\circ$

What if we use an irregular pentagon? One with 5 sides but with unequal sides and angles? Cut out these pentagons and find a way to tessellate them. Work out what each angle must be. Remember the angles at the join must equal 360° .

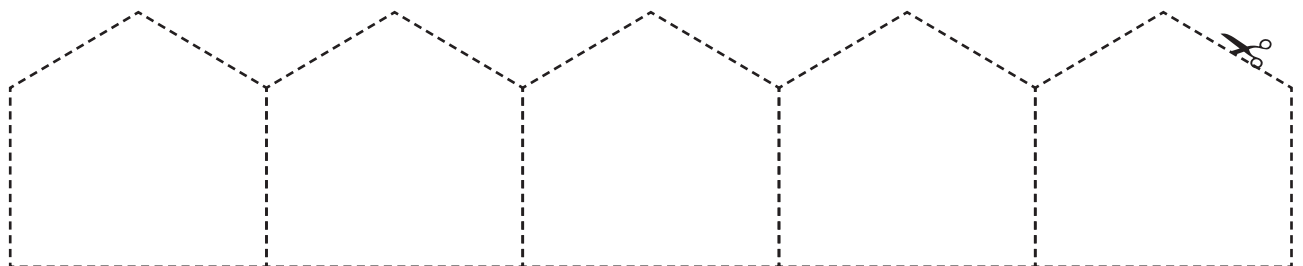

Transformation, tessellation and symmetry – enlargement and reduction

We can use grids to help us enlarge or reduce pictures. We do this by changing the size of the grid or the number of cells a picture uses.

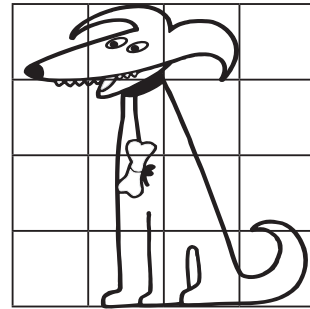
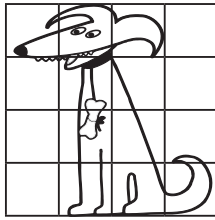

1 Enlarge or reduce each shape:

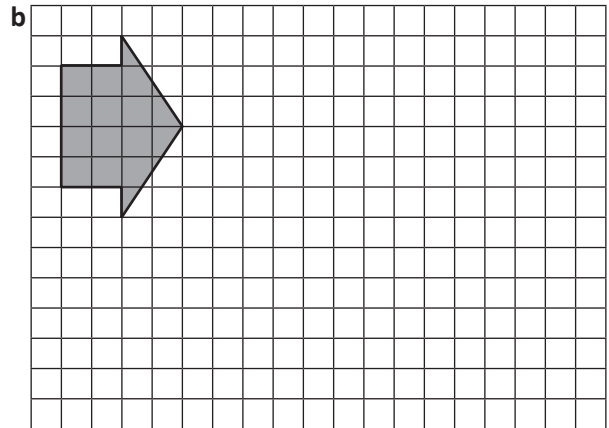
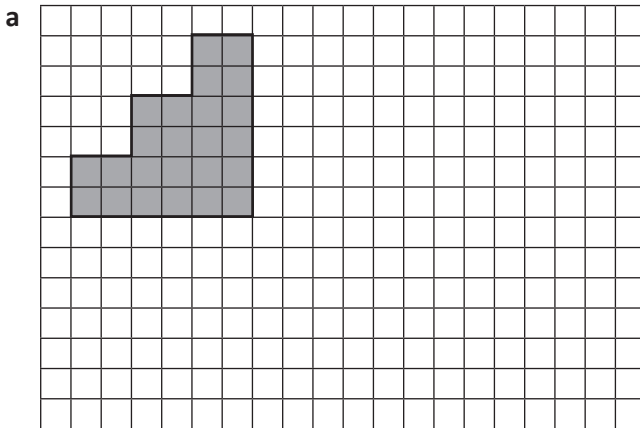

2 Compare the pictures below and answer the following questions:

a Look at the outline of the 2 pictures.
How much longer is Picture 2 compared to Picture 1 (from top to bottom)?

b Have the angles changed?

c Has the shape been rotated?

d Has the area changed?

Picture 1

Picture 2

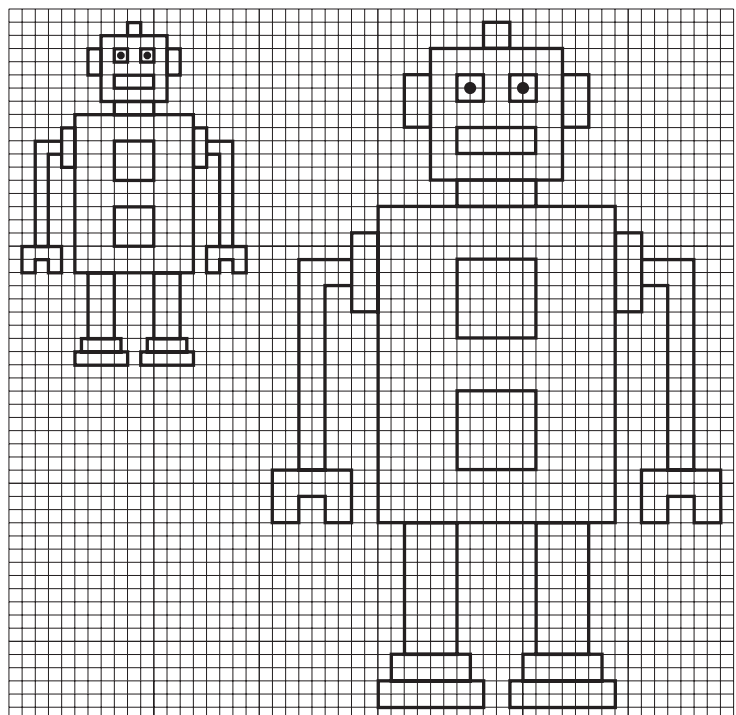



Getting ready



You're going to draw a picture for a partner on the small grid. You'll then swap pictures with your partner and enlarge each other's pictures.

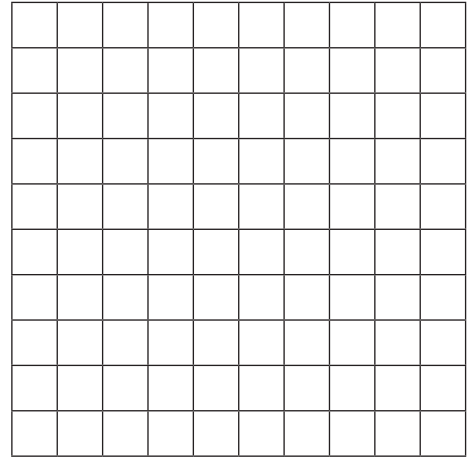

What to do



Choose a picture to create. Keep it simple and decide if you want to colour it or keep it black and white. You may want to sketch it on scrap paper first.



What to do next



Switch pictures with your partner and recreate their masterpiece as a larger masterpiece.

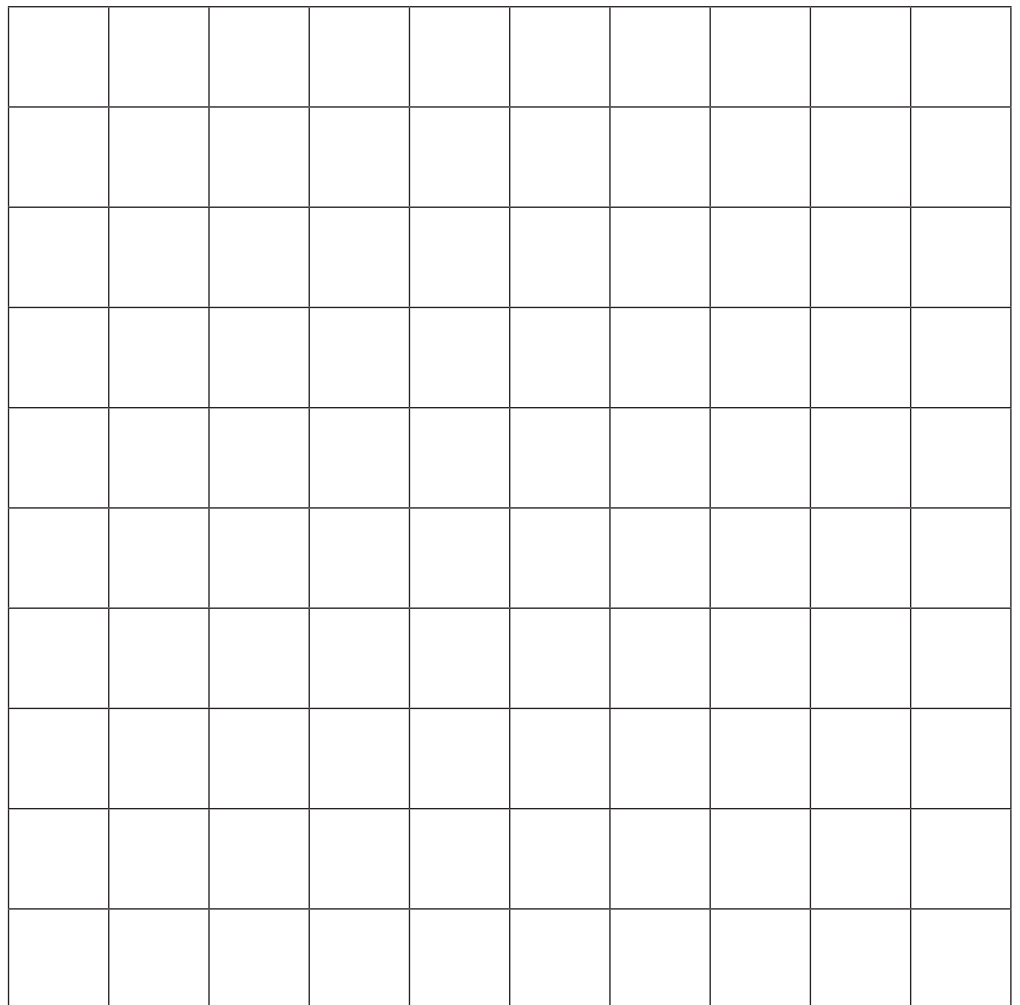



Many cultures and art styles use tessellations as a basis for creating intricate and beautiful patterns. You will use this tessellated grid as a basis for your own eye-catching design.

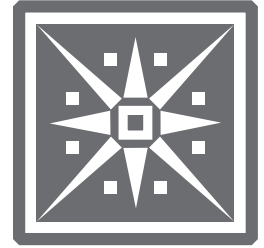

Choose one of the designs on the left to recreate on this grid **or** create one of your own:

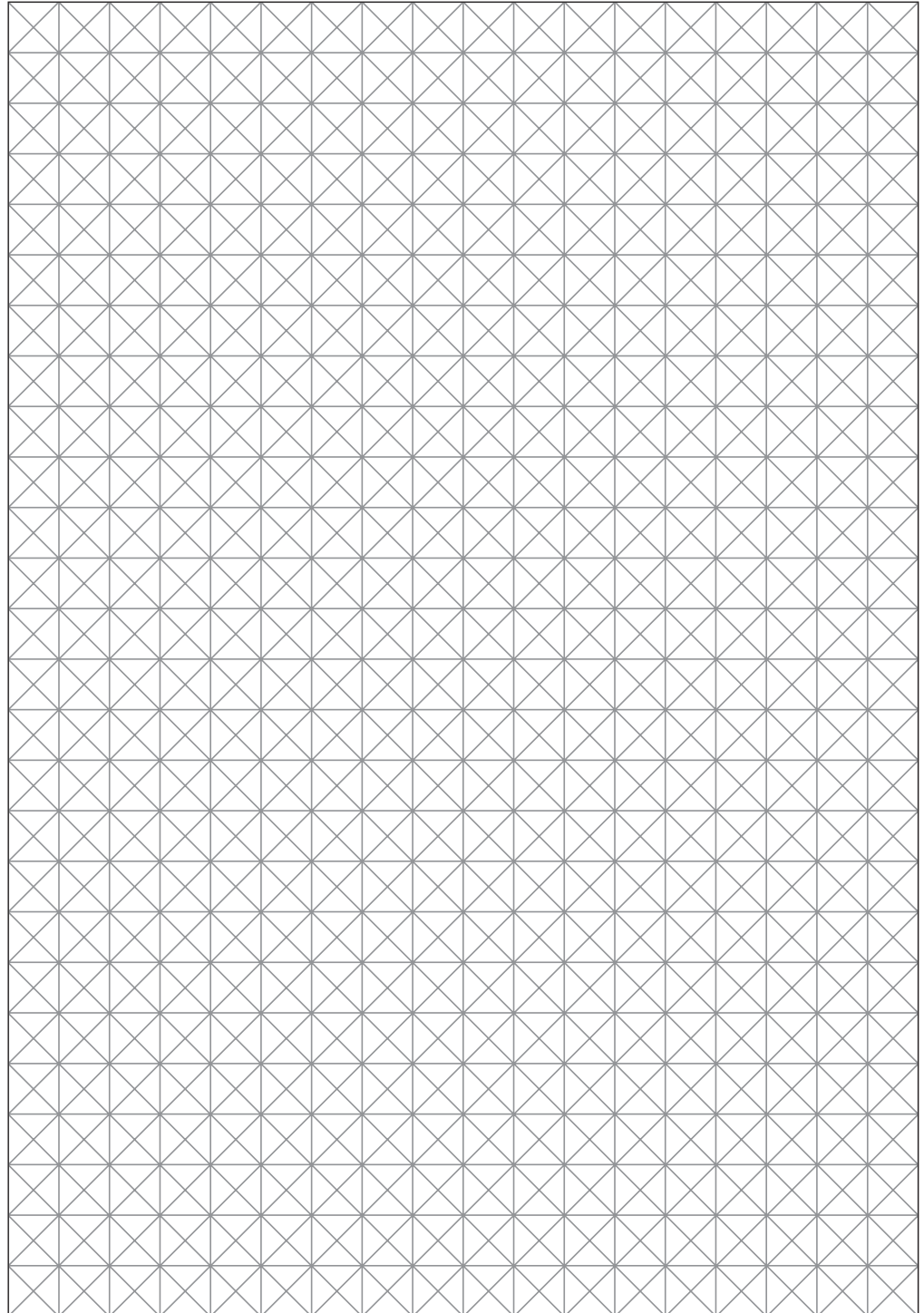
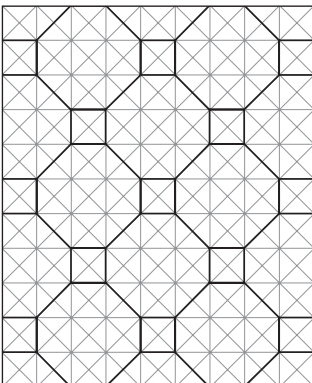
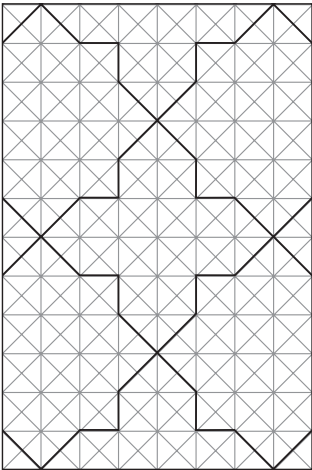
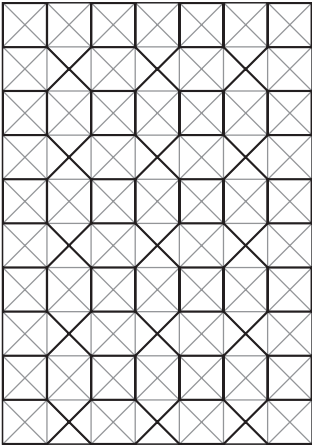

3D shapes – types and properties

- 1 How do 3D shapes differ from 2D shapes? Imagine you're giving an explanation to a younger child. What would you say and/or draw?

Remember the **surfaces** of a 3D shape are 2D shapes. Where 2 surfaces meet is called the **edge**. The **point** where 2 or more surfaces meet is called the **vertex**. If we are talking about more than one vertex we call them **vertices**.

- 2 How many surfaces, edges and vertices does each of these shapes have?

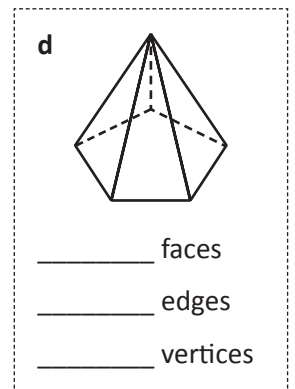
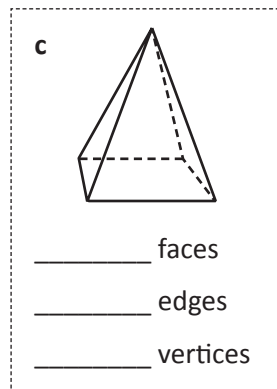
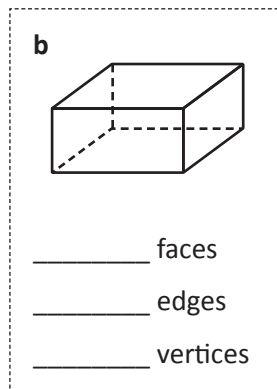
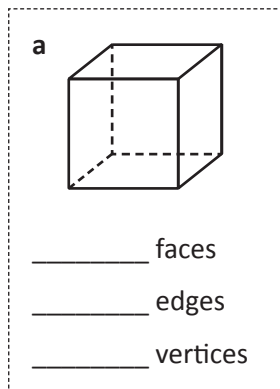

Some 3D shapes are **polyhedrons**. This means each surface is a polygon. The polyhedrons we most commonly come across are pyramids and prisms.

Prisms have identical parallel faces joined by rectangles. Most prisms are named after their end faces.

Pyramids have a base with 3 or more straight sides. They have triangular faces which meet at a point. They are named after their bases.

Another group of 3D shapes has one or more curved surfaces (e.g. spheres, cones and cylinders).

- 3 Complete the following:

a Draw one type of prism.
How many faces, edges and vertices does it have?

___ faces ___ edges ___ vertices

b Draw one type of pyramid.
How many faces, edges and vertices does it have?

___ faces ___ edges ___ vertices

c Draw a shape with one or more curved surface.
How many faces, edges and vertices does it have?

___ faces ___ edges ___ vertices

3D shapes – types and properties

4 You and a partner have 20 minutes to identify as many of these mystery 3D shapes as you can. Use whatever resources you have to assist you – maths dictionaries, websites, Mathletics or solid shapes. Different shapes are assigned different point values, so decide which answers you will spend the most time on! You can score a possible 150 points. At the end of the 20 minutes your answers will be checked and your scores tallied.

a I have 3 faces.
One of these is curved.
The other 2 faces are
2D circles.
These circles are parallel
to each other.
I'm a

5

b This is an example of me:

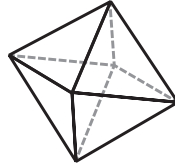

I'm an

20

c I have a square base and
4 triangular faces.
The triangular faces meet
together at one point.
I'm a

10

d I have 1 curved face, no
vertices and no edges.
I roll well.
I'm a

5

e I have two names.
One of these is hexahedron.
I have 6 faces, 8 vertices
and 12 edges.
Draw me.

10

f This is an
example
of me:



I have 20 faces, 12 vertices
and 30 edges.
I'm an

10

g I'm a Platonic solid.
This means all my faces,
angles, vertices and edges
are identical.
I have 4 faces.
I'm a

20

h I'm not a polyhedron.
I have a flat circular base
and 1 curved face.
I have 1 vertex.
I'm a

10

i This is an example of me:

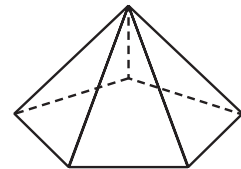

I'm a

5

j This is an example of me:

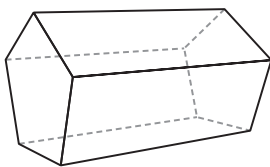

I'm a

5

k This is an example of me:



What is my name (and it's
not donut)?
I'm a

50

Our total score:

Did any pairs in the class
score a perfect 150?

3D shapes – types and properties

A Swiss mathematician called Leonhard Euler, found a mathematical rule that was so important, it was named after him. He wasn't just a pretty face ... He discovered a connection between the number of faces (F), number of edges (E) and number of vertices (V) of polyhedrons.



Here is part of Euler's rule: $F + V - E = \boxed{?}$

5 Your job is to try and work out what should go in the box. Because we are incredibly nice people we'll give you the following hints:

- The answer is a number.
- You should find the missing information in the table below. Use solids to help you.
- Then, for each shape, try $F + V - E$ and see what your answer is. It should always be the same. If not, you've gone wrong somewhere.

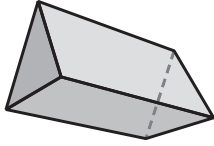
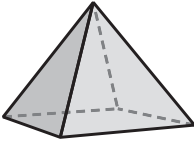
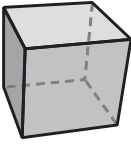
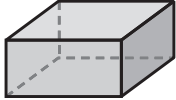
Polyhedron	Triangular prism	Square based pyramid	Cube	Rectangular prism
Number of faces (F)				
Number of vertices (V)				
Number of edges (E)				
Formula	 $F + V - E =$ ___ + ___ - ___ = ___	 $F + V - E =$ ___ + ___ - ___ = ___	 $F + V - E =$ ___ + ___ - ___ = ___	 $F + V - E =$ ___ + ___ - ___ = ___

What is Euler's formula? $F + V - E =$ _____

6 Find 2 more polyhedrons to test this out on:

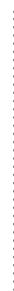

It took Euler years to work this out and you've done it straight away. Well done! We suggest you take the rest of the day off. Just run it by your teacher, we're sure they'll be up for it.

3D shapes – nets

A net is the pattern of a 3D shape, unfolded and laid flat. It helps to visualise how nets fold up to create a 3D shape.

1 Fold each net 'in your head' then write its letter in the correct shape name box at the bottom of the page:

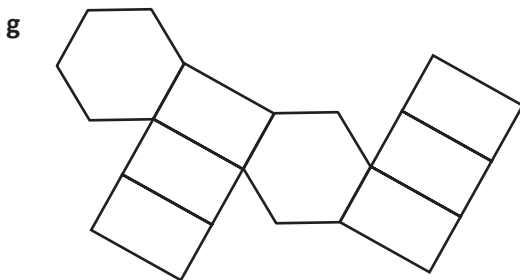
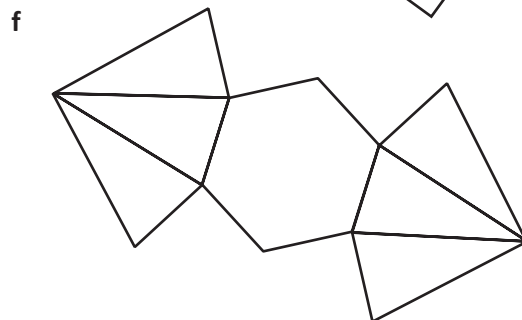
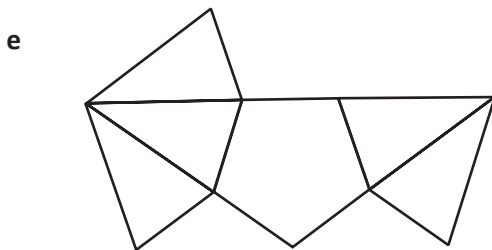
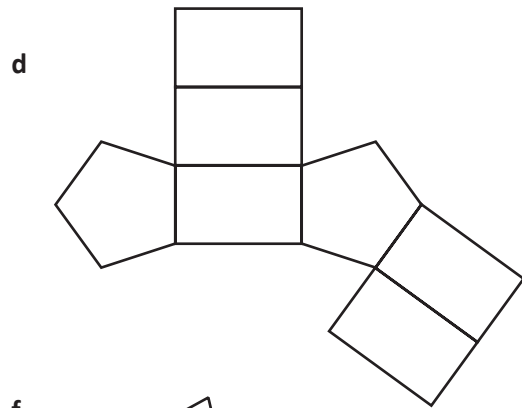
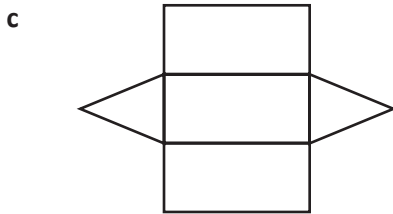
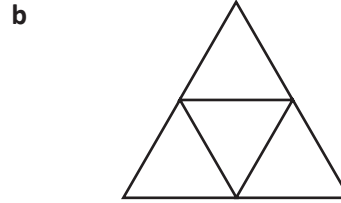
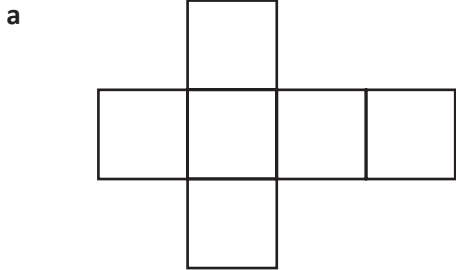

Remember the difference between prisms and pyramids!



REMEMBER

pentagonal pyramid	triangular pyramid	hexagonal prism	
triangular prism	pentagonal prism	hexagonal pyramid	cube

3D shapes – drawing 3D shapes

When we draw 3D shapes, we can draw dotted lines to indicate the surfaces, edges and vertices we can't see.

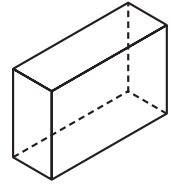

1 Add the dotted lines to these shapes to reveal the missing edges and vertices. The name of the shape may guide you – a square based pyramid needs a square for its base and a rectangular prism has rectangles at each end.

a

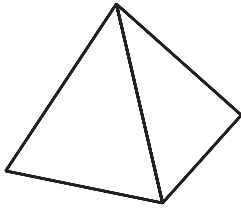

square based pyramid

b

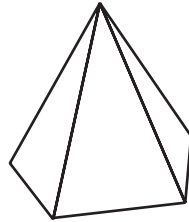

pentagon based pyramid

c

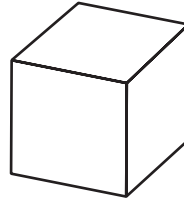

cube

d

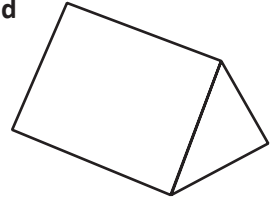

triangular prism

e

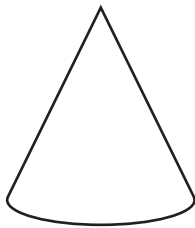

cone

f

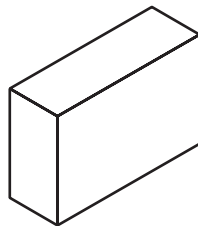

rectangular prism

g

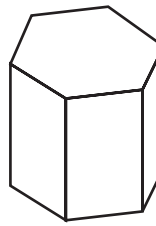

hexagonal prism

h

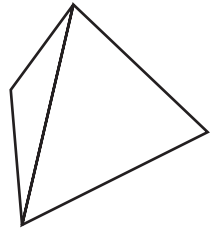

triangular based pyramid

2 Draw the following shapes:

a triangular prism

a cylinder

a pentagonal based pyramid

a cone

3D shapes – drawing 3D shapes

3 Use the following information to help you identify and draw this mystery shape:

- I have 4 identical faces.
- I have 4 vertices and 6 edges.
- My base is a triangle.
- At each vertex, 3 faces meet.

I'm a _____

4 Now choose your own 3D shape and write a set of directions so that a partner can identify and draw it:

We can also use isometric dot paper or hexagonal grids to guide us when we draw 3D objects.

5 Use the dot paper to draw a cube, a rectangular prism and a triangular pyramid. The first one has been done for you.

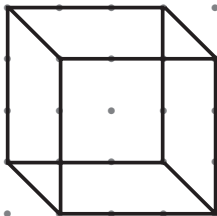

This paper only works if the dots form vertical lines.



DISCOVER



Getting ready



Cubes have six faces and can be created from a number of nets. Your job is to find them all. Work with a partner.

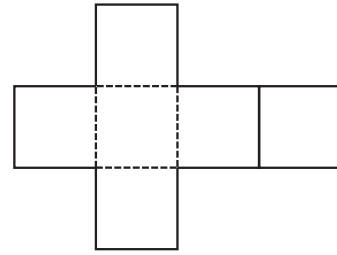

copy



What to do



How many nets can you find that will fold to make a cube? Use the grid below to help you draw and test your designs. You may need a few copies of the grid.



Getting ready

Look at the 3D shapes below. Can you line them up so each shape shares the same face with the one next to it? They don't have to be the same size, but the faces must match. It will help to use solids.



What to do

It may help to name each shape and list its 2D faces. The first one has been done for you. Work with a partner and record your solution. You may like to describe it or perhaps take a digital photograph.

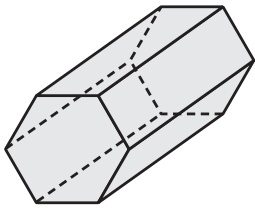

hexagonal prism

- *hexagon*
- *rectangle*

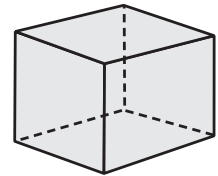
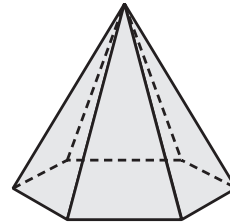
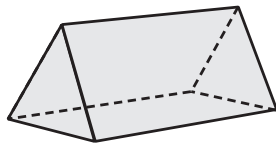
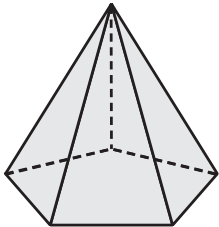
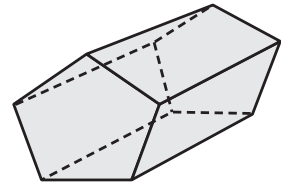
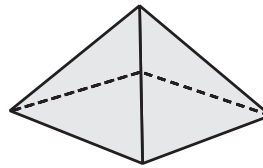
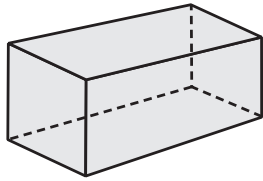

What to do next

Can you find more than one solution? How many can you find?
Can you make a loop with the shapes?